

OLIVE

JUST FRUITS & EXOTICS

30 ST. FRANCES ST.

CRAWFORDVILLE FL 32327

OFFICE: 850-926-5644 FAX: 850-926-9885

JUSTFRUITS@HOTMAIL.COM

WWW.JUSTFRUITSANDEXOTICS.COM

INTRODUCTION

We were really excited when we found out it was possible to grow Olive trees in the South. After many trials with several varieties, we found that the Arbequina was the only consistent fruiter for us and it's self-fertile! These impressive, long-lived trees require two things to be happy: temperatures above 10°F in the winter and 300 hours of chill to bear fruit. The trees are gorgeous evergreens with misty gray foliage. They are fast growers and will bear in 3 to 4 years. The fruit is picked green and pickled for green olives, or allowed to ripen to black for crushing into olive oil or making salted black olives.

USES IN THE LANDSCAPE

Olive trees have a classic Mediterranean look - gray and willowy. One of the most adaptable of trees, Olives can be planted out to grow into large shade trees, trained to espalier or grown in containers. You can use Olive trees to create an Italian garden, with rosemary, oregano and other Mediterranean herbs. Plant salt-tolerant Olives near the seashore, surrounded by lantanas and plumbago. Train an elegant weeping Olive against a sunny wall. Use Olives, trained as standards, in large containers for a formal look around a pool or on a patio.

PLANTING AND CULTURE

SITE SELECTION

Olives will grow in a wide range of soils, as long as good drainage is provided. Olives are among the most tolerant of high soil salinity of all fruit trees. Pick a sunny, well-drained spot.

SOIL PREPARATION AND PLANTING

Prepare the planting hole by enriching with organic matter (50:50 mix of soil and organic matter). The planting hole should be approximately twice as big as the pot and twice as deep.

Remove the olive tree from the pot, gently loosen the root ball and place in the planting hole. The olive should be planted **at or slightly above** the same level at which it grew in the pot. Fill the

planting hole with the mix of soil and organic matter; gently tamp it in. Water thoroughly to settle the roots and eliminate air pockets. Do NOT put fertilizer in the planting hole. Only apply fertilizer if it is the correct time of year (see Fertilization section below). If desired, construct a water basin around the base of the olive approximately 36 inches in diameter.

Spacing of trees is dependent upon how you wish to prune them (more on that later). Trees that will be grown to full size should be planted 30 feet apart in Zone 9 and 20 feet apart in Zone 8b.

WATER

Olives are very drought tolerant once established. After planting, make sure trees receive approximately 1 inch of water per week for the first year. Water regularly for the best fruit production.

FERTILIZATION

We use and recommend the Espoma line of organic fertilizers. Espoma's Citrus Tone is a good choice for olive trees. When not available look for an organic mix that contains an analyst of roughly 5-2-6. Make sure they contain iron, zinc, manganese, magnesium, molybdenum, copper and boron. These minor elements are very important to plants and most soils are low in these elements. Application rates vary according to type and age of plant, so read the instructions on the bag and fertilize accordingly. Be sure to spread the fertilizer evenly under the entire canopy of the plant avoiding a 2-inch area around the trunk. Water or rake in. For Zones 8b-9, fertilize 3 times each year in February, May and late July/early August. Never fertilize after August as this will promote new growth when the plant needs to go dormant.

FRUIT PRODUCTION

Arbequina olive trees are self pollinating. This means that a single tree will set fruit. While bee activity is not required for fruit set, there is evidence that fruit set is greater if bees have visited the olive flowers.

Olives tend to bear heavily in alternate years. You can help insure good crops every year by having a bee-friendly habitat, preventing over-bearing, and fertilizing properly. Mature Olive trees rarely require thinning, but juvenile trees sometimes set more fruit than they can support, a condition called over-bearing. Over-bearing can lead to reduced fruit size and quality, possible limb damage, and reduced vigor and fruit set the following year. For the largest possible olives, and stronger trees, thin to 2 or 3 fruit per foot of twig as soon as possible after fruit set.

Established trees will survive and fruit with considerable neglect, but, like all fruits, reward the attentive gardener with better fruit and more bountiful harvests.

PRUNING AND SHAPING

Olive trees can be grown in the orchard, in containers and as espalier. Espalier trees should be trained to the desired shape. Leave wood from the previous season's growth for successful fruit production. For trees grown in containers or in the orchard, 3 branches are selected to serve as scaffold branches in the first year. For the next 3 to 4 years, remove suckers and water sprouts as well as any damaged or crossing branches. During this growth and establishment stage, pruning should be kept to the minimum. A secondary scaffold system of 3 branches may be developed from the main scaffold branches.

Olive fruits are borne on the previous year's growth. Most fruit is carried in a shell 2 to 3 feet deep around the outer edge of the tree. Pruning of an established tree should be done to promote a continuous supply of new fruiting wood and to keep the bearing zone vigorous. Excessive pruning will reduce fruit crops and increase vegetative growth. Olives require good light for fruiting and should not be spaced too closely together, or planted in shade.

If trees are damaged by frost, wait until the next June or July to prune to avoid removing limbs that may survive and fruit. Remove damaged or dead branches. Young trees (1-2 year old) are more vulnerable to frost than are older trees. If temperatures are expected to drop into the mid-20°F, wrap the trunks of young trees with insulation for protection.

PESTS AND DISEASES

Olive scale and peacock leaf spot can damage olive crops. However, in 20 years of growing olives, we've never had problems. Be sure to provide excellent drainage, ample sun, and avoid over watering.

HARVESTING AND STORAGE

Harvesting depends upon how you wish to process the olives. Green olives should be picked when some of the fruit have a purple-black tinge to them. Black olives are picked when fully darkened. The easiest way to pick olives is to place a tarpaulin under the tree and either hand pick or use a rake with widely spaced teeth. In the Mediterranean, trees are hit with a long pole to harvest the fruit and thin the tree slightly. All olives must be processed before eating.

RECIPES

We are including two ideas for processing your olives: preserving your olives and making your own olive oil. We would love to hear about other delicious possibilities.

PRESERVING OLIVES

Gather fruit and rinse thoroughly. Place on a clean hard surface and bruise the fruit or prick with a fork. This helps the salt and water penetrate the fruit. Put the olives in a bucket of water with $\frac{1}{2}$ cup coarse salt per 10 cups water. Place a lid on top of the bucket to keep the olives submerged.

Change the water each day, replacing with fresh salted water. Continue this for about 12 days for green olives or 10 days for black olives. To test the olives, bite one. When the bitterness has nearly gone, the olives need a final salting. Pour off the last of the salted water and measure it so you will know how much is required. Measure out the same quantity of water and add 1 cup salt for each 10 cups of water. Bring to a boil and allow to cool.

Place olives in jars or bottles and pour the salty brine to cover. Top the jars with $\frac{1}{2}$ inch of olive oil and attach lids. This stops air infiltration and seals the olives. Olives will keep for approximately 12 months in the cupboard.

Before eating, drain the salty brine and fill the bottles with cool water. Refrigerate for 24 hours. If olives are still too salty, fill the bottles with warm water and refrigerate again for 24 hours. Once the correct salt level has been reached, experiment with adding different combinations of herbs and spices. Try rosemary, oregano, garlic, hot pepper or lemon. Enjoy!

HOMEMADE OLIVE OIL (adapted from Agricultural Sciences, University of California Leaflet 278)

PRESSING THE OLIVES

A simple press may be made from easily obtained materials, as follows: a heavy automobile jack; 2 large flat pieces of pine plank 2 x 12 x 12 inches; a shallow water-tight tray at least 16 x 16 inches fitted with a juice spout and resting on a base of 2- or 3 inch lumber; a framework (preferably of hardwood) of 2 x 6 inch lumber (see illustration).

Olives should be boiled for a short time to soften them, then placed in a strong sack and crushed thoroughly with a heavy mallet or the broad side of an ax. Place the crushed fruit and pits in a heavy piece of burlap and fold the edges of the burlap to give a press cake of about 10 x 10 x 4 inches. Make two of these, then place them between the two pieces of pine plank and apply pressure with the jack. Press slowly until no more juice is obtained. Save all juice and oil. The pressed pulp should now be boiled with an equal volume of water and pressed again. Usually a third and fourth heating and pressing are desirable. Combine all the pressed liquid and allow it to stand overnight. The oil can then be skimmed off.

WASHING THE OIL

Oil initially will be bitter and cloudy. It must be washed with water to remove the bitterness and rough flavor. First prepare a bucket or 5 gallon can with a hole and faucet near the bottom. Place the oil in the container and add an equal amount of warm water. Mix by stirring for several minutes. Allow the water to settle for several hours. Draw off the water and replace with fresh warm water. Repeat until the oil no longer has a bitter taste. Usually 2 days washing will be sufficient.

FILTERING THE OIL

The oil will be cloudy and mixed with a little water. It can be cleared by filtration. A 7-inch diameter funnel and filter paper or coffee filters are needed. Place the funnel and filter in a wide-mouthed bottle. Pour the oil into the funnel and allow to filter. Oil filters slowly - it may take several days for the oil to run through the filter.

New olive oil does not have a good flavor. It should be kept for several months in well-cleaned

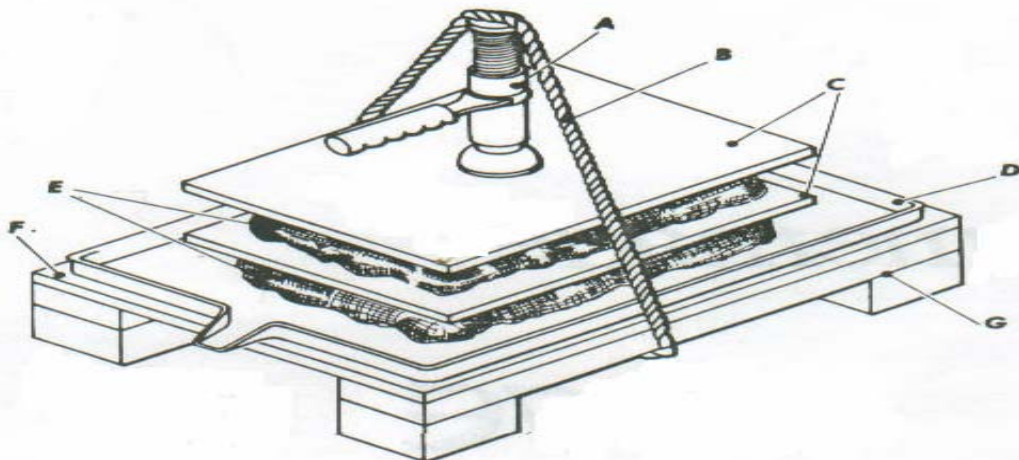

A, heavy automobile jack; B, light steel cable or 1-inch rope; C, two pieces of 2 x 12 x 12 inch pine plank; D, tin-lined sheet metal pan at least 16 x 16 inches with juice spout as shown (or wooden trough of same dimensions); E, heavy cloth to hold fruit; F, base of 2- or preferably 3-inch material; G, frame of 2 x 6 inch lumber, preferably hardwood.

bottles away from bright light. Too much light will cause it to lose color and flavor. A warm room will speed the aging process. It will also age more quickly if the bottles are $\frac{3}{4}$ full and stoppered with cotton.